



ASTRA DUO 38
SEE-THROUGH FIREPLACE

supr^{me}

WARMTH AND SECURITY.

OUR STATE-OF-THE-ART SEE-THROUGH FIREPLACES

COME STANDARD WITH EXCLUSIVE FEATURES ALLOWING FOR TOTAL CONTROL OF YOUR FIRE WITH SAFETY AND EFFICIENCY.

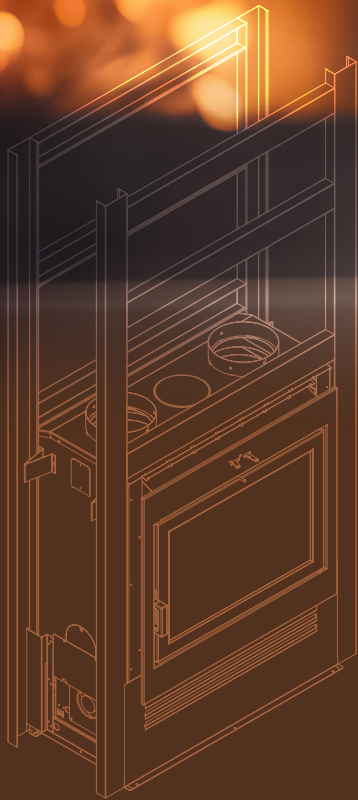

Supreme Fireplaces blend seamlessly into any home or business, offering warmth, comfort, and style. With customizable designs that enhance any space, they provide efficiency, durability, and aesthetic appeal, making them a perfect choice for both personal and professional settings.



SEE-THROUGH FIREPLACE
ASTRA DUO 38
TRADITIONAL

SPECIFICATIONS

HEAT CAPACITY : 1,000 to 2,500 sq. ft.

HEATING TIME : 6 to 12 hours

FIREBOX SIZE : 3.8 cu ft

GLASS DIMENSIONS : 22 7/8" x 15 3/8"

MAX. HEAT OUTPUT : 125,000 BTUs

LOG SIZE : Up to 23"

EMISSIONS : 2.16 g/hr

CHIMNEY : 6" listed to UL103/
ULC S629 standards



Astra Duo 38 shown with traditional surround

PATENTED AUTOMATIC AIR CONTROL

This patented, user-friendly mechanism automatically reduces the amount of combustion air introduced during ignition to the desired burn rate setting. The result is a beautifully consistent fire burning to its full capacity.

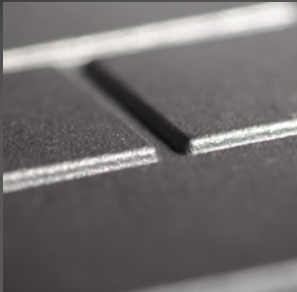

REVERSIBLE CAST IRON PANELS

Crafted with care, our heavy-duty cast iron panels are stamped with a brick pattern on one side and a flowing contemporary design on the other. These reversible panels provide a versatile design that is as beautiful as it is functional.

QUALITY CONSTRUCTION

Supreme manufactures high-quality fireplaces by combining advanced engineering with premium materials like steel for durability and efficiency. Their fireplaces feature airtight combustion systems for optimal heat output and energy efficiency, while also offering sleek, stylish designs to suit various interiors.



SEE-THROUGH FIREPLACE
ASTRA DUO 38
CLEAN FACE

SPECIFICATIONS

HEAT CAPACITY : 1,000 to 2,500 sq.ft.

HEATING TIME : 6 to 12 hours

FIREBOX SIZE : 3.8 cu ft

GLASS DIMENSIONS : 22 7/8" x 15 3/8"

MAX. HEAT OUTPUT : 125,000 BTUs

LOG SIZE : Up to 23"

EMISSIONS : 2.16 g/hr

CHIMNEY : 6" listed to UL103/
ULC S629 standards



Astra Duo 38 shown with clean face
surround and square grills



**BUILT WITH STRENGTH.
DESIGNED FOR WARMTH.**

The framing structure of a see-through fireplace requires careful planning, as it must support the fireplace unit while accommodating openings on both sides. Built with non-combustible materials, the framing ensures proper ventilation and heat management. Its versatility can be integrated into walls between living spaces, dividing rooms while maintaining visual continuity. This structural design enhances the aesthetic appeal of modern homes and maximizes the fireplace's functional value by heating two areas simultaneously.

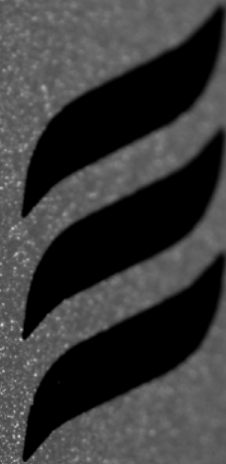
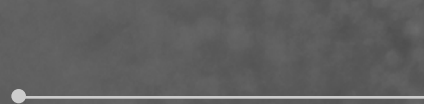

UNIQUE DOOR OPERATION

The dual blower system helps distribute the convection heat more efficiently into the room. As the combustion progresses, the blowers automatically activate with the heat and can be set using the variable speed control.



DUAL BLOWER SYSTEM (165 CFM)

The dual blower system helps distribute the convection heat more efficiently into the room. As the combustion progresses, the blowers automatically activate with the heat and can be set using the variable speed control.

H O W T H E A S T R A D U O 3 8 W O R K S

A Crafted with care, our heavy-duty cast iron panels are stamped with a brick pattern on one side and a flowing contemporary design on the other. These reversible panels provide a versatile design that is as beautiful as it is functional.

A Crafted with care, our heavy-duty cast iron panels are stamped with a brick pattern on one side and a flowing contemporary design on the other. These reversible panels provide a versatile design that is as beautiful as it is functional.

B Crafted with care, our heavy-duty cast iron panels are stamped with a brick pattern on one side and a flowing contemporary design on the other. These reversible panels provide a versatile design that is as beautiful as it is functional.

C Crafted with care, our heavy-duty cast iron panels are stamped with a brick pattern on one side and a flowing contemporary design on the other. These reversible panels provide a versatile design that is as beautiful as it is functional.

Crafted with care, our heavy-duty cast iron panels are stamped with a brick pattern on one side and a flowing contemporary design on the other. These reversible panels provide a versatile design that is as beautiful as it is functional.

B Crafted with care, our heavy-duty cast iron panels are stamped with a brick pattern on one side and a flowing contemporary design on the other. These reversible panels provide a versatile design that is as beautiful as it is functional.

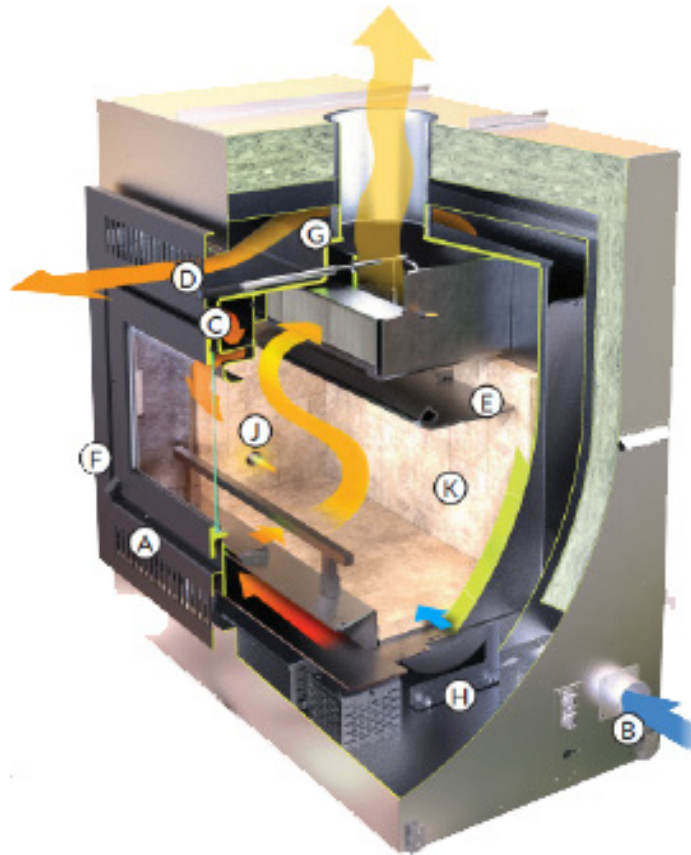

A Crafted with care, our heavy-duty cast iron panels are stamped with a brick pattern on one side and a flowing contemporary design on the other. These reversible panels provide a versatile design that is as beautiful as it is functional.

A Crafted with care, our heavy-duty cast iron panels are stamped with a brick pattern on one side and a flowing contemporary design on the other. These reversible panels provide a versatile design that is as beautiful as it is functional.

A Crafted with care, our heavy-duty cast iron panels are stamped with a brick pattern on one side and a flowing contemporary design on the other. These reversible panels provide a versatile design that is as beautiful as it is functional.

A Crafted with care, our heavy-duty cast iron panels are stamped with a brick pattern on one side and a flowing contemporary design on the other. These reversible panels provide a versatile design that is as beautiful as it is functional.

Crafted with care, our heavy-duty cast iron panels are stamped with a brick pattern on one side and a flowing contemporary design on the other. These reversible panels provide a versatile design that is as beautiful as it is functional.

A Crafted with care, our heavy-duty cast iron panels are stamped with a brick pattern on one side and a flowing contemporary design on the other. These reversible panels provide a versatile design that is as beautiful as it is functional.



SUPREME WARRANTY

SUPREME INC. warrants its factory-built fireplaces will be free from defects in material and workmanship, under normal use and service, for a period of ten (10) years from the date of purchase.

Astra Duo 38 Traditional

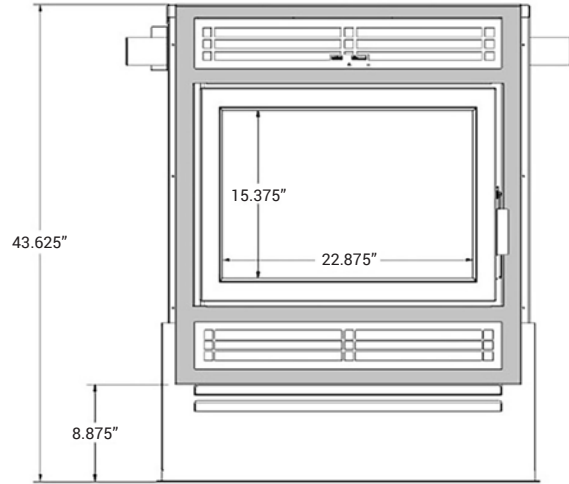

FRONT VIEW

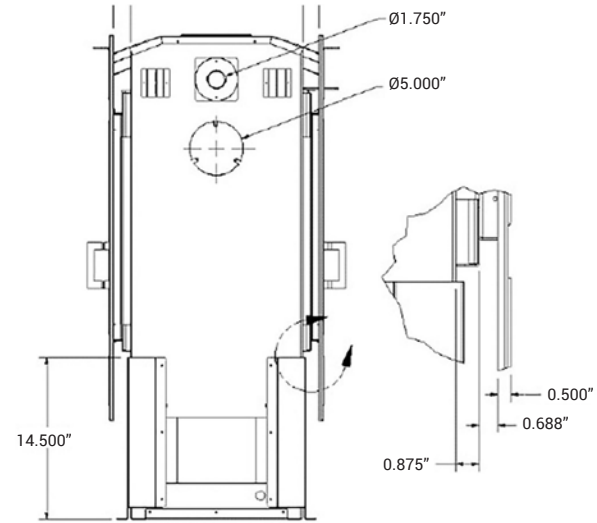

SIDE VIEW

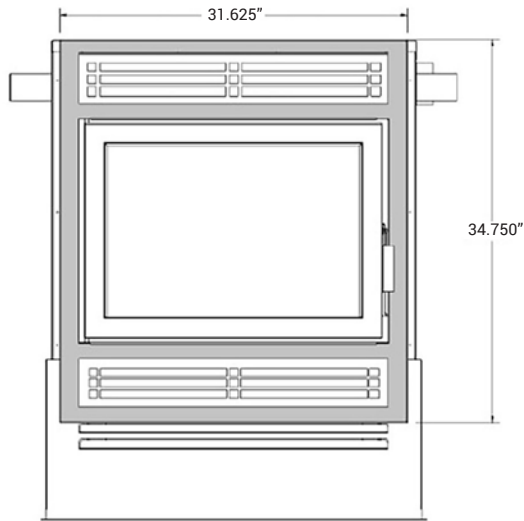

BACK VIEW

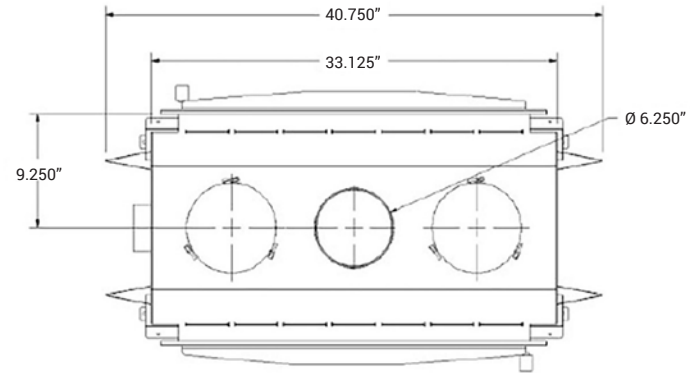

TOP VIEW

D I M E N S I O N S

Weight: 340 lbs

Astra Duo 38 Clean Face

D I M E N S I O N S

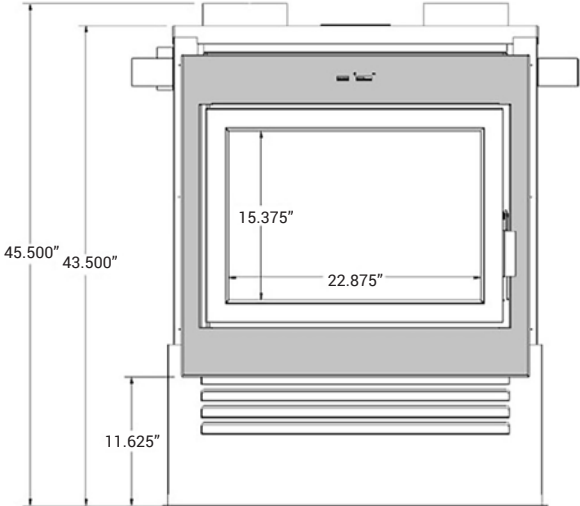

FRONT VIEW

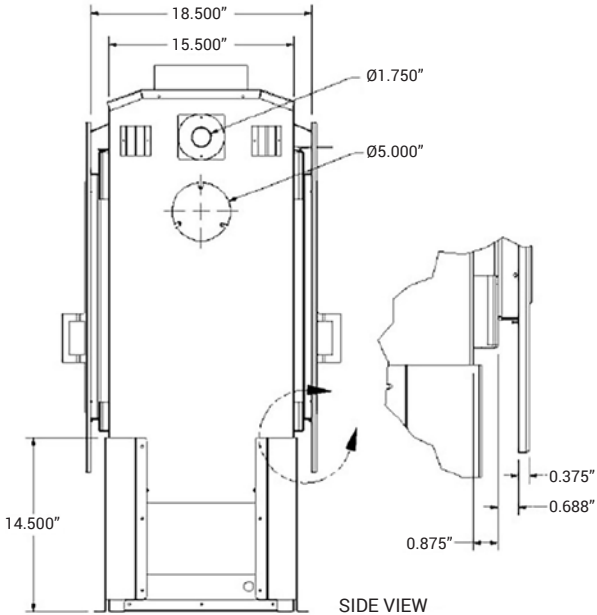

SIDE VIEW

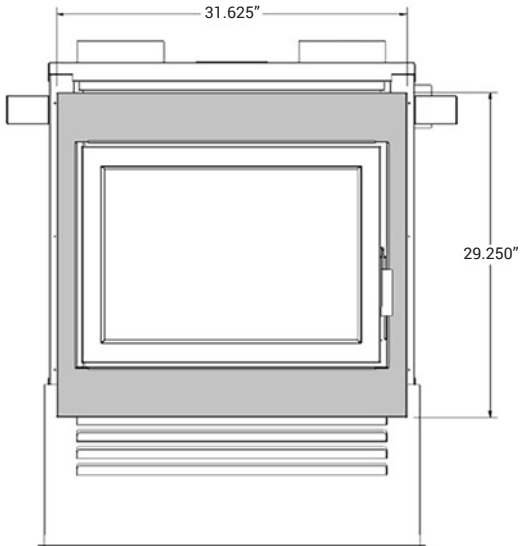

BACK VIEW

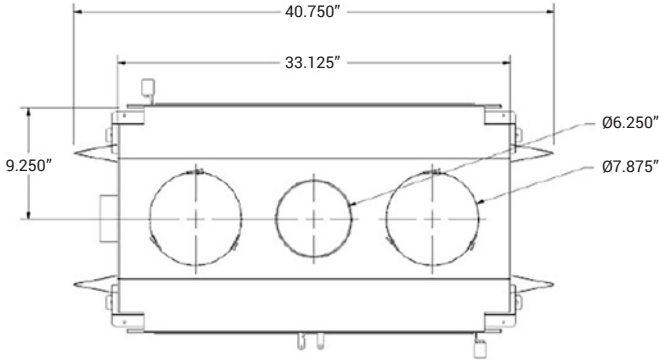

TOP VIEW

Weight: 340 lbs

Astra Duo 38 Framing

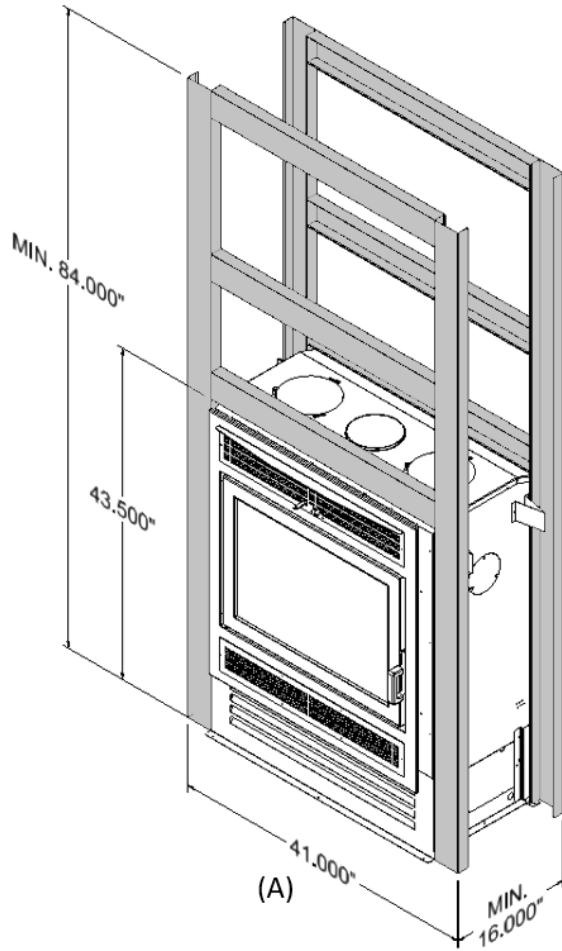

A) Traditional Surround Configuration

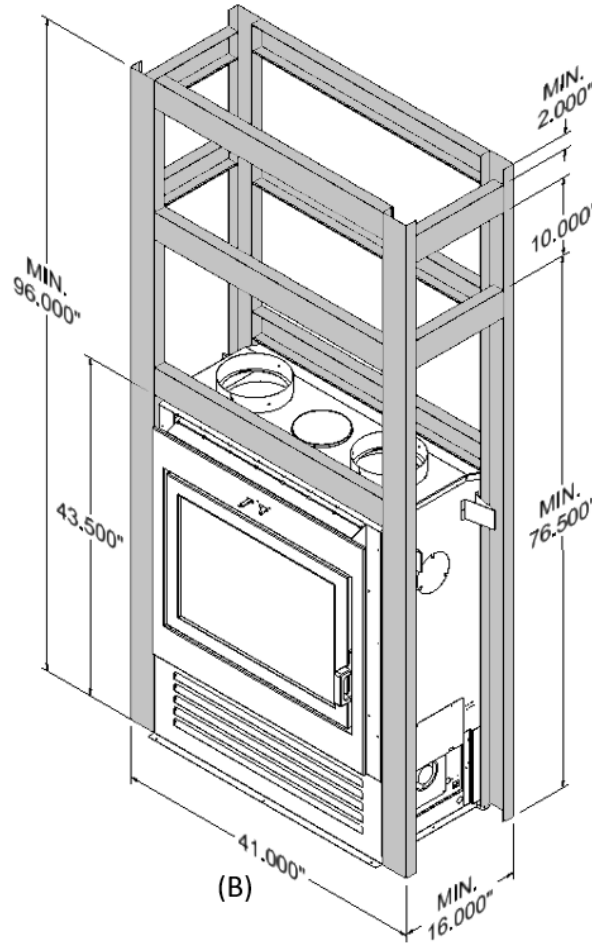

(B) Contemporary Surround with Side Wall 8" Gravity Ducts

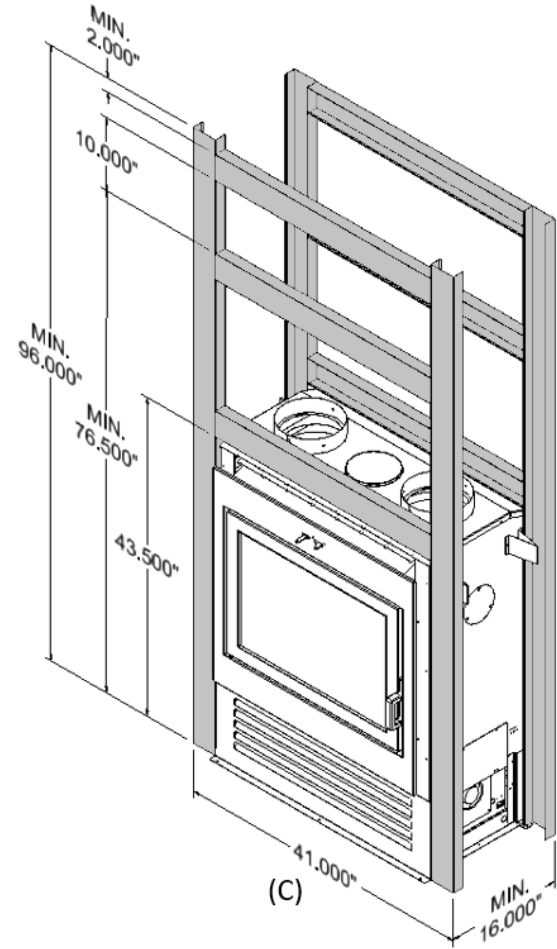

(C) Contemporary Surround with Front or Back Wall 8" Gravity Ducts



supr^{me}

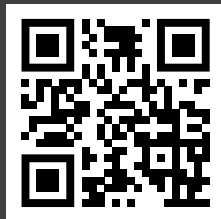

3594 Jarry East, Montreal, Quebec H1Z 2G4

Telephone: 514.593.4722 Toll-free: 1.877.593.4722 Fax: 514.593.4424

www.supremem.com | info@supremem.com

Information and images contained in this catalog are subject to change and should be used for reference only.
All installations should be done in accordance to the specifications detailed in the owner's manual.